

Product description

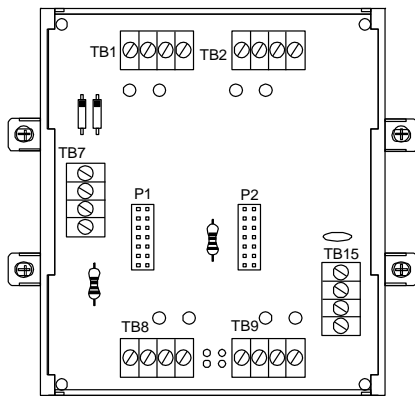

The Signature Series Universal Input/Output Motherboard (model SIGA-UIO2R) provides mounting and wiring terminations for up to two Signature M series modules. The motherboard features individual inputs/outputs and a common input/output bus. Jumpers, located between the modules, facilitate sharing of common inputs/outputs between the two modules to reduce wiring.

The motherboard mounts in an MFC-A cabinet or other suitable equipment enclosure with screws and washers provided. Each MFC-A will hold one SIGA-UIO2RF motherboard complete with their full complement of modules. See “Specifications” for a list of compatible enclosures.

Modules plug into the motherboard in either location, and captive screws fasten them to the motherboard. All module field wiring goes to terminal blocks on the motherboard to permit rapid removal and replacement for troubleshooting.

Specifications

Capacity: Two M series plug-in modules

Terminal capacity: 12 AWG (2.5 sq mm) to 18 AWG (0.75 sq mm)

Compatible boxes: MFC-A, 2-WB(X) series, 3-CAB series, RACCR series, 3-RCC series, or any UL listed fire alarm enclosure that meets clearance requirements below and complies with the “Installation Instructions”

Clearance space: 1 inch minimum all around the SIGA-UIO2R, 1/2 inch above the M series modules, and in accordance with the National Electrical Code

Dimensions (H x W x D): 4.30 in (10.9 cm) x 5.34 in (13.5 cm) x 0.87 in (2.2 cm) + 2.25 in (5.7 cm) module depth

Storage temperature: -4 to 140 °F (-20 to 60 °C)

Operating environment

Temperature: 32 to 120 °F (0 to 49 °C)

Humidity: 93% RH, noncondensing at 90 °F (32 °C)

Installation instructions

In cabinets that house only one motherboard:

- Group all modules with nonpower-limited sources to the right of the motherboard and route their wiring to the right
- Group all modules with power-limited sources to the left of the motherboard and route their wiring to the left

- Maintain 1/4-inch separation between power-limited and nonpower-limited wiring, or use FPL, FPLR, FPLP, or an equivalent in accordance with the National Electric Code

Installations with multiple motherboards or enclosures that include other wiring require FPL, FPLR, FPLP, or equivalent NEC-approved wiring for all power-limited wiring.

Observe supervision and power-limited vs. nonpower-limited circuits, as found on the M series installation sheets.

WARNING: Disconnect power to cabinets before installing or removing components. Failure to do so may result in serious injury or loss of life.

To install the SIGA-UIO2R:

1. See “Specifications” to determine the correct enclosure and clearance space for the motherboard.
2. Use the motherboard to mark the mounting hole locations.
3. Drill 0.125 in (3.175 mm) mounting holes.
4. Mount the motherboard in the cabinet using the screws and washers provided.

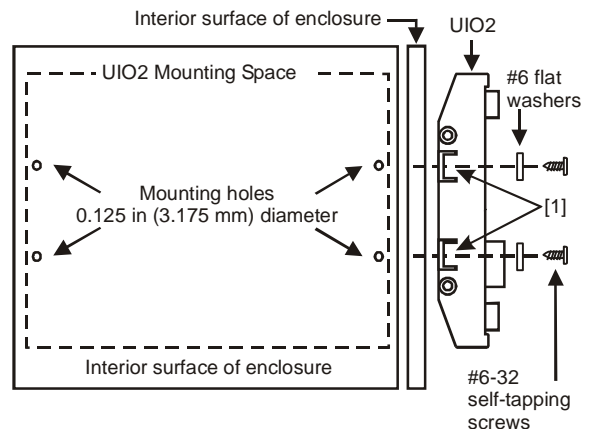

Notes

- [1] Mark the mounting hole locations here
2. See the installation sheets of the individual M series modules for mounting instructions to the motherboard

Wiring diagrams

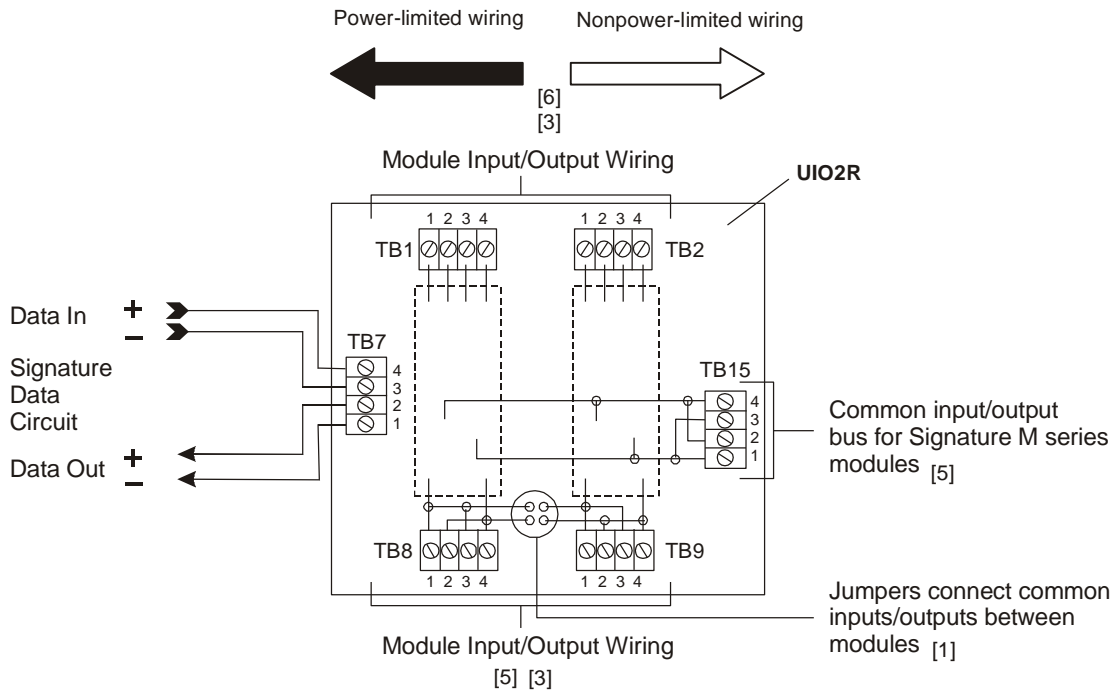

Notes

- [1] Jumpers may be used to make the inputs/outputs between modules common
2. Not all modules use the motherboard terminals for the same functions
- [3] Refer to individual Signature M series installation sheets for jumper settings and wiring information
4. Do not mix incompatible signals
- [5] Maximum current is 8 amps
- [6] Maintain 1/4 in (6.4 mm) separation between power-limited and nonpower-limited wiring
7. Wire size must be capable of handling fault current from nonpower-limited source.
8. Signature Data Circuit Class A or Class B.